

This coursework is individual task. The coursework submission must be prepared by the individual student.

[Coursework Description]

1) Estimate the manufacturing cost for a bearing housing following the data sheet.

Materials and dimensions of the bearing housing will depend on your student number. The example of bearing housing drawings in default dimension is provided in the Appendix section of this document. Solidworks part files are provided in the Blackboard for your reference.

If your Student Number is 123456 (corresponding to ABCDEF):

Materials:	
Pedestal (top/base):	B is even: mild steel; B is odd: aluminium
Bearing, pin:	C is even: stainless steel; C is odd: brass
Assume extra 1.5mm per machined side for raw material billets/bars.	

Dimensions (see Appendix):	
Length of Pedestal base = $84 + D =$ mm
$= 104 + D =$ mm
Height of Pedestal base = $60 + E =$ mm
Diameter of hole in bearing = $32 - F =$ mm

2) The Bearing housing assembly is comprised of 4 components, plus fasteners:

1. Base of the pedestal
2. Top of the pedestal
3. Bearing (plain bearing for rapidly rotating shafts)
4. Locking Pin (interference fitting with bearing, loose fitting with pedestal)
 - a. Two threaded studs (fasteners)
 - b. Two nuts (and washers) (fasteners)

3) Use Solidworks databases for the definition of material properties (such as material densities) and for the selection of suitable fasteners (Design library\ Solidworks toolbox). Alternatively, the following external resource would be useful for obtaining the material properties:

- Matweb (www.matweb.com)

The Solidworks model can be used to calculate the volume removal (i.e. "Quantity" in the costing worksheet) for each of the manufacturing process, and at the same time, capturing the images for the manufacturing process route(s).

Alternatively, hand calculation can be applied to input the equivalent volume removal. Also, hand sketch and/or PowerPoint drawing or equivalent would be acceptable, in lieu of the Solidworks captured images.

[Requirements]

The student is required to submit the following two completed documents (1 and 2).

1. A completed Costing Sheet (template provided) comprised of

1.1) An individual costing worksheet with detailed description of the selected manufacturing process route:

- Worksheet "Assembly"
- Worksheet "Pedestal Base"
- Worksheet "Pedestal Top"
- Worksheet "Bearing"
- Worksheet "Pin"

[10 points]

1.2) Use the given worksheet "Tolerance Bearing" and define tolerance fitting required for the Bearing:

- Bearing fitting to the Pedestal Top
- Bearing fitting to the Pedestal Base
- Bearing fitting to the Pin

[3 points]

1.3) Use the given worksheet "Summary" and complete the necessary information:

- Table detailing cost for parts and assembly
- Table and Pie-charts detailing cost of materials and manufacturing processing (machining, set-up, assembly, etc.)

[5 points]

1.4) Use the given worksheet "Stud" and estimate the cost of making the threaded studs in lieu of buying off-the-shelf fasteners, assuming alloy steel. Comment on the results.

[2 points]

2. A4 sized PDF document(s)* answering the following:

*the document(s) can be either descriptive (your own thoughts in written text, a single page max) or reproduced technical drawings saved in PDF format via Solidworks.

2.1) The example of bearing housing drawings in default dimension is provided in the Appendix section of this document. Considering the BSI/ISO standards for producing the technical drawings, how would you update and reproduce the drawings by paying close attention to the assembly, dimension, tolerance and surface finish?

[Assembly]

- Any other information or dimension needs to be included here?

[Dimension]

- All the part drawings correctly dimensioned?

[Tolerance and Surface finish]

- Any thoughts on general tolerance and surface finish, reflecting your raw material and chosen manufacturing process routes?

- Any thoughts on specific tolerance and surface finish, considering the fitting and assembly?

[10 points]

TOTAL [30 points]

[Submission]

Please submit **electronically** completed College of Engineering Cover Sheet, together with the completed worksheet (**Excel**) and any other supplementary documents providing answers to the **Requirements** in **PDF format** to the link

Note: Late submission will receive zero marks

[Marking Scheme]

Criteria	0-10% (Poor)	20-30% (Deficient)	40% (Mediocre)	50% (Adequate)	60% (Competent)	70-80% (Very Good)	90-100% (Excellent)	Mark
1. Costing Sheet 1.1) Calculation	No calculation. Copy and pasted info from the example.	Incorrect calculations. Irrelevant selection of manufacturing processes and steps. Clear lack of understanding.	Many omissions or errors but some relevant calculations are correct; insufficient effort in carrying out costing for all given parts.	Adequate calculations. Some aspects of the costing not completed or not fully investigated.	Competent but some minor errors in calculations.	Very well presented with accurate calculations. Evidence of clear understanding of manufacturing process and costing.	Excellent costing sheet. Clear understanding on manufacturing process and costing. Faultless.	/5
1.1) Detailed description of each manufacturing process route - Base - Top - Bearing - Pin	Missing.	Some descriptions are given but no details (i.e. covering the major manufacturing processes from a billet/round bar to a final machined piece with grinding and polish if needed).	Limited efforts, some critical errors in understanding manufacturing processes. Missing major process routes.	Adequate descriptions. Some aspects of the process route not completed or not fully investigated.	Consistent effort and good descriptions. Only occasional mistakes in writing.	Very good effort and consistency shown throughout. Very good understanding on manufacturing processes.	Excellent effort; clear and consistent understanding on manufacturing process route shown throughout. Evidence of supplementary reading; faultless.	/5
1.2) Tolerance fitting required for the pin - Bearing fitting to Pedestal Top/Base and Pin	Little work done, many major errors.	Not specified with hole/shaft basis tolerance fitting.	Minimal effort in carrying out the tolerance fitting. Inappropriate selection of tolerance application (too tight or too loose fitting).	Largely adequate use and selection of appropriate tolerance fitting. Some inconsistencies between the values indicated here and the drawing(s).	Competent but some minor errors in the selection of tolerance values.	Very good understanding on tolerance fitting. Some minor mistakes on tolerance values; some improvements possible.	Clear and consistent. Excellent understanding on tolerance fitting in consideration of relevant application and operational conditions.	/3
1.3) Summary a) Table detailing cost for parts/assembly b) Table and Pie-charts detailing cost of materials and manufacturing processes	No summary given (no change from a template).	Failed to show understanding of manufacturing process and costing. No effort shown.	Minimal effort in carrying out the summary. Limited understanding of manufacturing process and costing. Misses some important details. Inaccurate costs.	Most of the main points or details have been covered but improvements possible. Adequate effort shown.	Clear evidence of understanding of manufacturing process and costing. Clear logical table and charts that connects summary in a seamless fashion.	Very good effort. Professional standard with accuracy. Clear evidence that the summary demonstrates one's in depth understanding of manufacturing process and costing.	Excellent summary. Demonstrated with table and charts to explain the costing breakdown effectively. Clear understanding of manufacturing process and costing. Faultless.	/5
1.4) Cost of making threaded studs - Costing - Comment (description on the result)	Cost estimation missing.	Limited evidence of one's effort. Badly presented. Clear deficiency in understanding of manufacturing process and costing.	Minimal effort in carrying out the work. Limited understanding of manufacturing process and costing. Misses some important details. Inaccurate costs.	Most of the main manufacturing process and costing have been covered but improvements possible. Adequate effort shown.	Competent but some minor errors in the calculations. Presentation and description can be improved.	Very good understanding on manufacturing process and costing. Consistency shown throughout.	Clear and consistent. Excellent understanding on manufacturing process and costing. Clear comparison made between buy and make threaded studs.	/2
2. Engineering Drawings - Assembly - Dimension - Tolerance and Surface finish	No efforts. Submitted document(s) do not take the BS/ISO standards into account.	Limited evidence of one's effort. Badly presented. Clear deficiency in understanding the BS/ISO standards of assembly, dimensioning, tolerance and surface finish.	Minimal effort in carrying out the work. Understanding the BS/ISO standards on assembly, dimension, tolerance and/or surface finish at times incorrect or unclear.	Moderate effort. Largely adequate understanding of relevant dimension, tolerance and surface finish in view of assembly. Reasonable presentation.	Competent understanding. Only occasional mistake or ambiguity. Some inconsistencies between the costing sheet information (manufacturing process) and descriptions/drawings.	Very good effort. Clear understanding of engineering drawings. Very well presented. Some minor mistakes or typos.	Excellent understanding. Professionally presented considering the BS/ISO standards. No improvement possible.	/10
							TOTAL	/30

[Appendix] Bearing Housing Drawings (in default dimensions)

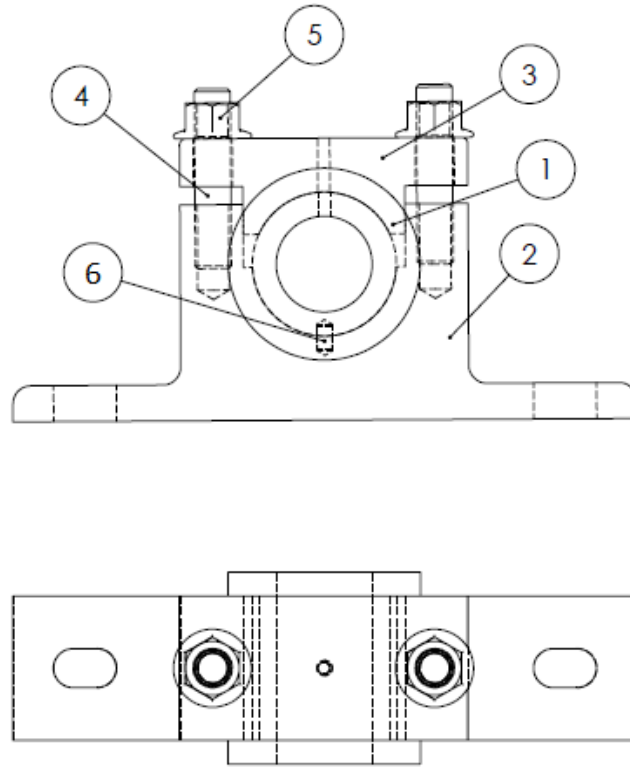

ITEM NO.	PART NUMBER	DESCRIPTION	QTY.
1	bearing		1
2	Pedestal Base		1
3	Pedestal top		1
4	AM -- M12 x 60 C		2
5	B18.2.2.4M - Hex flange nut, M12 x 1.75 --N		2
6	pin		1

UNLESS OTHERWISE SPECIFIED: DIMENSIONS ARE IN MILLIMETERS		FINISH:		DEBUR AND BREAK SHARP EDGES		DO NOT SCALE DRAWING		REVISION	
SURFACE FINISH:						STUDENT NAME ABCDEF			
TOLERANCES: LINEAR: ANGULAR:						TITLE: Assembly			
NAME	SIGNATURE	DATE				DWG. NO.		A4	
DRAWN									
CHKD									
APPVD									
MFG	SolidWorks Student Edition.								
Q.A	For Academic Use Only.								
		WEIGHT:		SCALE:1:2		SHEET 1 OF 1			

[Figure A-1]

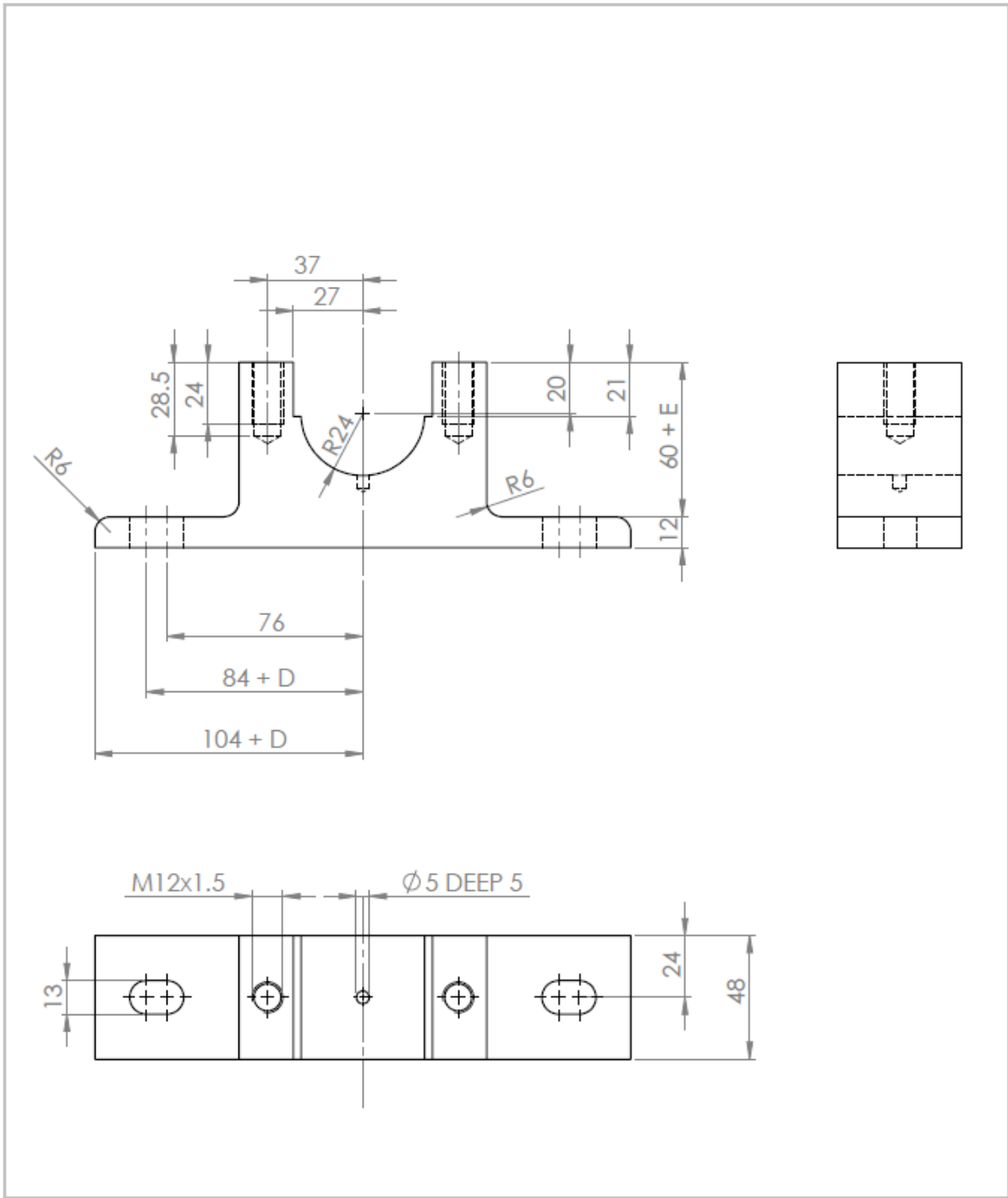

UNLESS OTHERWISE SPECIFIED: DIMENSIONS ARE IN MILLIMETERS		FINISH:		DEBUR AND BREAK SHARP EDGES		DO NOT SCALE DRAWING		REVISION	
SURFACE FINISH:									
TOLERANCES:									
LINEAR:									
ANGULAR:									
DRAWN		NAME	SIGNATURE	DATE	TITLE:				
CHK'D					Pedestal base				
APP'V'D									
MFG		SolidWorks Student Edition.			DWG NO.				
Q.A		For Academic Use Only.			A4				
		WEIGHT:			SCALE:1:2		SHEET 1 OF 1		

[Figure A-2]

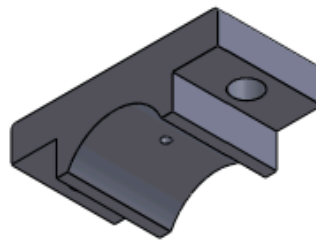
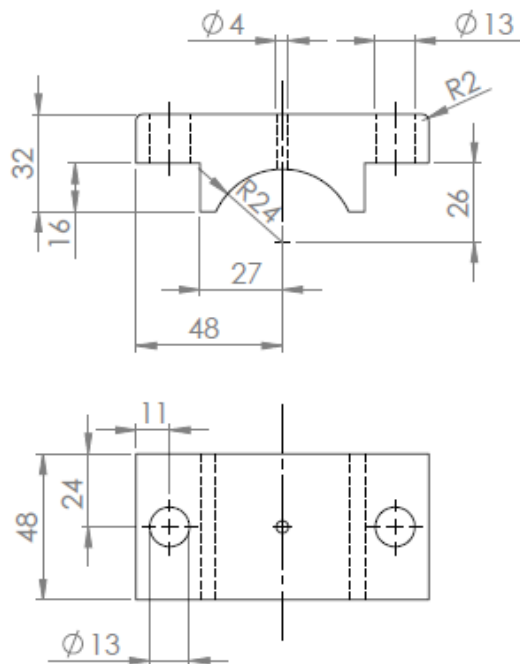

UNLESS OTHERWISE SPECIFIED: DIMENSIONS ARE IN MILLIMETERS		FINISH:		DEBUR AND BREAK SHARP EDGES		DO NOT SCALE DRAWING		REVISION	
SURFACE FINISH:									
TOLERANCES:									
LINEAR:									
ANGULAR:									
NAME		SIGNATURE		DATE		TITLE:			
DRAWN						Pedestal top			
CHK'D									
APP'V'D									
MFG									
Q.A						DWG NO.		A4	
				WEIGHT:		SCALE:1:2		SHEET 1 OF 1	

[Figure A-3]

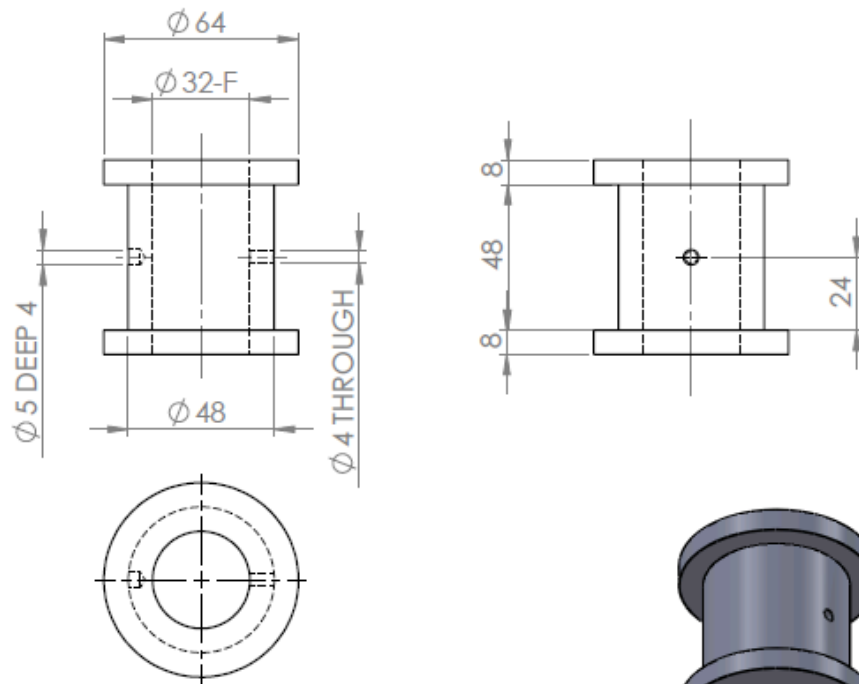

BEARING

PIN

Scale 1:1

UNLESS OTHERWISE SPECIFIED: DIMENSIONS ARE IN MILLIMETERS		FINISH:		DEBUR AND BREAK SHARP EDGES		DO NOT SCALE DRAWING		REVISION	
SURFACE FINISH:									
TOLERANCES:									
LINEAR:									
ANGULAR:									
DRAWN		NAME	SIGNATURE	DATE	TITLE:				
CHK'D					bearing and pin				
APP'V'D									
MFG									
Q.A									
		SolidWorks Student Edition. For Academic Use Only.			DWG NO.		A4		
		WEIGHT:			SCALE:1:2		SHEET 1 OF 1		

[Figure A-4]